

## **MS85P10/MS8510B Datasheet**

### **MShine Technologies Corporation**

#### HEAD QUARTER

2F, No. 1008, Sec. 4, Chung-Hsing Rd., Chu-Tung  
Township, Hsinchu, 310, Taiwan  
Tel: 886-3-5833899 Fax: 886-3-5830858

#### SHENZHEN OFFICE

Tel: 86-755-88250870  
Fax: 86-755-88250872

**Contents**

**CONTENTS..... 2**  
**FEATURES ..... 3**  
**BLOCK DIAGRAM..... 4**  
**APPLICATION..... 5**  
**PACKAGE..... 5**  
**GENERAL DESCRIPTION..... 5**  
**PINS CONFIGURATION..... 6**  
**PIN DESCRIPTIONS..... 7**  
**ABSOLUTE MAXIMUM RATINGS..... 7**  
**AC & DC ELECTRICAL CHARACTERISTICS ..... 8**  
**APPENDIX A. PACKAGE DIAGRAM ..... 10**

## Features

- n 8-bit micro-controller built in
- n **16K** bytes ROM (Read Only Memory)
- n 512+64 bytes RAM (Random Access Memory)
- n **Selectable Crystal/Resonator Clock Source: 3.58Mhz Resonator or 32768Hz clock+PLL.**
- n Programmable MCU clock rate
  - High speed : **3.58MHz, 1.79MHz, RC.**
  - Low speed : 32768Hz.
- n DTMF generator & Frequency Shift Keying (FSK) Generator
- n Ringer/Music tone generator
- n **Low voltage detector (LVD) / Comparator**
- n **Advance Power-On Reset** (Mask Option)
- n Two 8-bit general-purposed timers
- n A watchdog timer against deadlock.
- n Auto Key scan function (@ 1/8 duty mode)
- n Hook-detect interface (MPORT1)
- n Priority-based interrupts.
- n I/O ports and Multi-function I/O ports interface.
  - I/O port A: 8 pins general-purpose I/O ports with **Schmitt trigger interface**, and can interrupt independently.
  - I/O port B: **8** pins general-purpose I/O ports with non-open drain structure.
  - Open drain I/O port: **3** pins with heavy sinking capability. (PORT0~1, **MPORT0**)
- Multiple-function I/O ports: COM1~8, SEG1~24
- **Special hand-free control interface (2I/1O)**
  - HFIO,1: Hand-free Input**
  - HFO: Hand-free Output**
- n Auto Key-scan with LCD function.
- n UART function up to 115200BPS
- n Built-in LCD driver
  - Three programmable duties: 1/8 or 1/4
  - Two programmable biases: 1/4, or 1/3
  - Maximum 24 segment output pins
  - Maximum 8 common output pins
  - **32 level brightness adjustment**
- n Power Management
  - Standby mode
  - Stop mode
  - Programmable internal PLL
- n Operating voltage range: **2.0V~5.5V**
- n **IR Interface of 1/3 or 1/2 duty, with carrier of 37.9K, 40.0K, 56.7K.**

**Block Diagram**

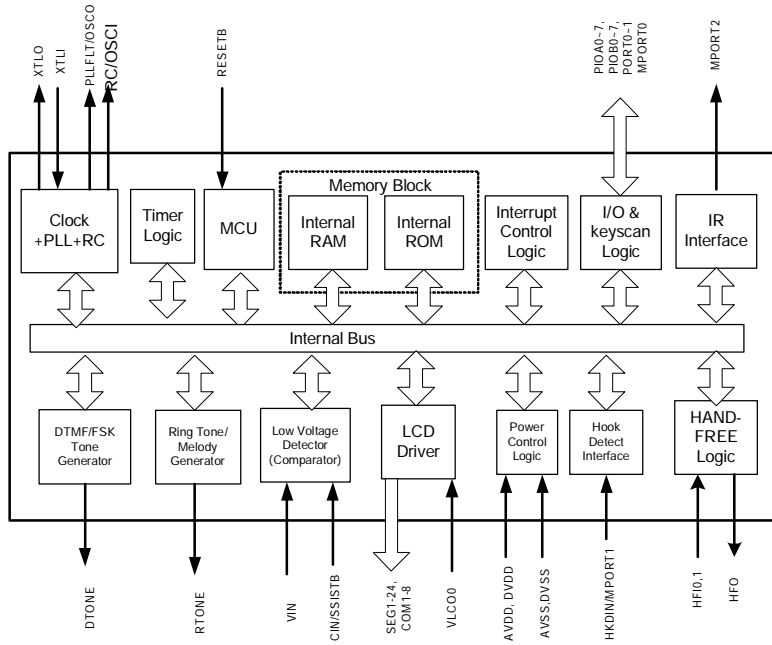

## **Application**

n Calculator, Phones, simple controllers.

## **Package**

n QFP 100 Packaged

## **General Description**

MS85P10 Series is suitable for calculator and phone applications. It has DTMF generator, Hand-Free interface, and hook-detection interfaces can be used to save hardware cost on normal phones. It also provides an RC oscillator that can be used for general controller applications.

**Pins Configuration**

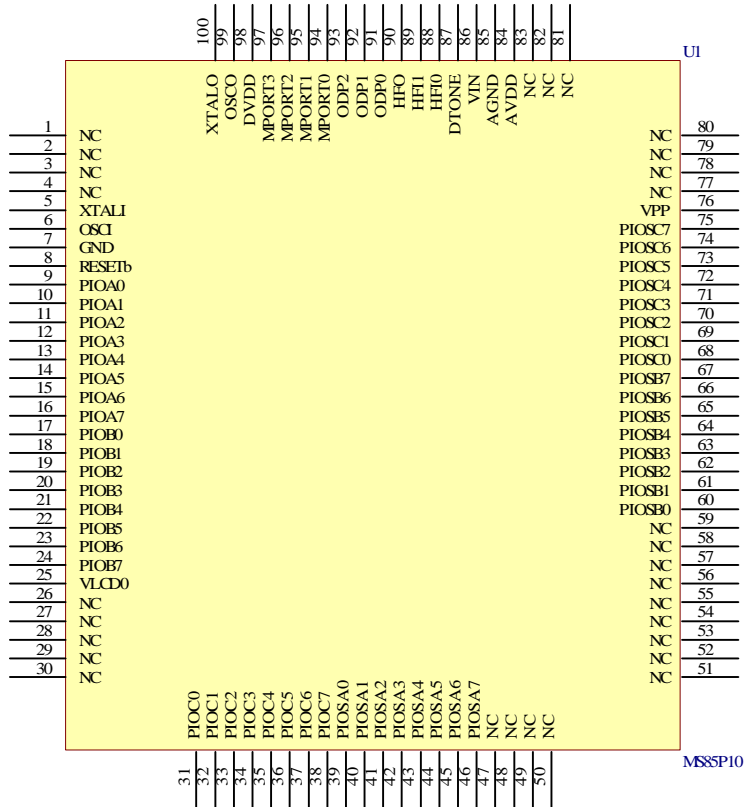

**Pin Descriptions**

Pin No.	Notation	I/O	Functional Description
	AVDD	Power	Analog power supply Input.
	AVSS	Power	Analog ground input.
	DVDD	Power	Digital power supply input
	DVSS	Power	Digital ground input.
	VLCD0	Power	Power source of LCD pins. This pin should have voltage greater or equal to DVDD.
	RESETB	I	Reset pin of the chip. Active low. Schmitter trigger built in.
	VPP	I	For MS85P10, this pin is used to give high voltage for programming. For mask part MS8510B, this pin is No-connection inside (NC).
<b>Miscellaneous Interface</b>			
	VIN	I	Low-voltage detector input.
<b>Oscillator &amp; Clock Generator Interface</b>			
	XTALO	O	32.768KHz oscillator output. A capacitor parallel connected to ground is required.
	XTALI	I	32.768KHz oscillator input. A capacitor parallel connected to ground is required.
	PLL_Filer	O	PLL Loop Filter Capacitor Pin. Connect to a resistor (typically R=1Kohm) and a capacitor(typically C=0.1uF)
	ROSC	O	RC oscillator connection. External Resistor to VDD should be connected.
<b>IO Pins</b>			
	PIOA0~7	I/O	Push-pull programmable I/O pin, with programmable internal pull-high resistor. This port is also used for key-scan input.
	PIOB0~7	I/O	Push-pull programmable I/O pin, with programmable internal pull-high resistor.
	PORT0,1,2	I/O	Open-drain structure I/O Pins.
	MPORT0~3	I/O	Programmable I/O Pins. MPORT0 pin is normal push-pull I/O pin with internal pull-high. MPORT1 pin has a hook-detect interface. MPORT2 pin is shared with IR interface. MPORT3 pin is also CIN input
<b>LCD Pins</b>			
	COM1~8	I/O	Common driver of LCD. These pins can also be configured as PIOC(OM)
	SEG1~24	I/O	Segment pins. These pins may also be configured as PIOSA, PIOSB, and PIOSC.

註解 [C1]: Power+reset = 6 pins

註解 [C2]: 1 pin

註解 [C3]: clock 4 pins

註解 [C4]: IO 23 pins

註解 [C5]: LCD 32 pins

**Absolute Maximum Ratings**
**Comments**

 DC Supply Voltage.....-0.5V to + 5.5V  
 Input Voltage.....-0.5V to VDD + 0.5V  
 Output Voltage.....-0.5V to VDD + 0.5V  
 Operating Temperature.....0° to 70° C  
 Storage Temperature.....-40° to 150° C

Never allow a stress to exceed the values listed under "Absolute Maximum Ratings", otherwise the device

would suffer from a permanent damage. Nor is a stress at the listed value be allowed to persist over a period, since an extended exposure to the absolute maximum

rating condition may also affect the reliability of the device, if not causing a damage thereof.

### AC & DC Electrical Characteristics

Parameters	Conditions	Symbol	Min.	Typ.	Max.	Unit
Supply voltage	MCU operating voltage	$V_{DD}$	1.8	3.6	5.5	V
	ROM operating voltage	$V_{ROMH}$	2.0	3.6	5.5	V
	RAM operating voltage	$V_{RAM}$	1.8	3.6	5.5	V
Supply current	<b>MCU Operating @ 3.58 MHz, 3.3V</b>			2.4		mA
	<b>MCU Operating @ 32768 Hz, 3.3V</b>			0.45		mA
	FSK/DTMF Generator Current Consumption	$I_{DTMF}$	-	<b>1.6</b>		mA
	Current Consumption of Low Speed MCU Mode (PLL off, 32.768KHz on, DTMF off, LCD on)	$I_{LSP}$	-	50		$\mu$ A
	Current Consumption of Standby Mode (PLL on, 32.768KHz on, DTMF off, LCD off)	$I_{PLL}$	-	<b>120</b>	-	$\mu$ A
	Current Consumption of Standby Mode (MCU off, PLL off, 32.768KHz on, DTMF off, LCD off)	$I_{STDY}$	-	<b>10</b>	-	$\mu$ A
	Current Consumption of Stop Mode (MCU off, PLL off, 32.768KHz off, DTMF off, LCD off)	$I_{STOP}$	-	1	3 <sup>1</sup>	$\mu$ A
Output voltage	$I_{OH}=1$ , Push-pull pins.	$V_{OH1}$	$V_{DD}-0.2$	-	-	V
	$I_{OL}=2$ mA, push-pull pins	$V_{OL1}$	0.2	-	-	V
	$I_{OL}=2.2$ mA, open-drain pins	$V_{OL2}$	0.2	-	-	V
Input voltage	All IO Pins	$V_{IH1}$	$0.8 V_{DD}$	-	$V_{DD}+0.3$	V
	All IO Pins	$V_{IL1}$	-0.3	-	$0.2 V_{DD}$	V
Output current	Push-pull pins, $V_{DD}=3.6V$ , $V_{OH}=-$	$I_{OH1}$		3		mA
	Push-pull pins	$I_{OL1}$		15 8		mA
	Open Drain pins	$I_{OL2}$		15 8		mA
Pull-up resistor	Push-pull pins	$R_{PULL}$	-	100	-	$K\Omega$
	PIOA, PIOB, selected by s/w	$R_{A,B,PULL}$	100		600	$K\Omega$

### AC Electrical Characteristics – DTMF Generator (Temperature=0°C to 70°C, $V_{DD}=3.3V$ , GND=0V)

Parameter	Symbol	Min.	Typ.	Max.	Unit
Operation Voltage	$V_{DD}$	1.8	3.3	5.5	Volt.
Operation Current	$I_{DD}$	-	800	-	$\mu$ A
Standby Power <sup>2</sup>	$I_{STB}$	-	1	TDB	$\mu$ A
DTMF Sink Current	$I_{TOL}$	-	200	-	$\mu$ A
DTMF Output DC Level	$V_{TDC}$	-	$0.5 \cdot V_{DD}$	-	Volt.
DTMF Output AC Level	$V_{TAC}$	-	$0.6 \cdot V_{DD}$	-	Vpp

<sup>1</sup> The leakage is from the “power on reset” (APOR) circuits of MS8506CP.

<sup>2</sup> Leakage is only when  $V_{DD}<2.0V$ .



Column Pre-emphasis	A <sub>CR</sub>	-	2	-	dB
DTMF Output Load	R <sub>L</sub>	5	-	-	kΩ
Tone Distortions	THD	-	-30	-23	dB
Propagation Delay Time	T <sub>PG</sub>			0.5	ms

**Appendix A. Package Diagram**

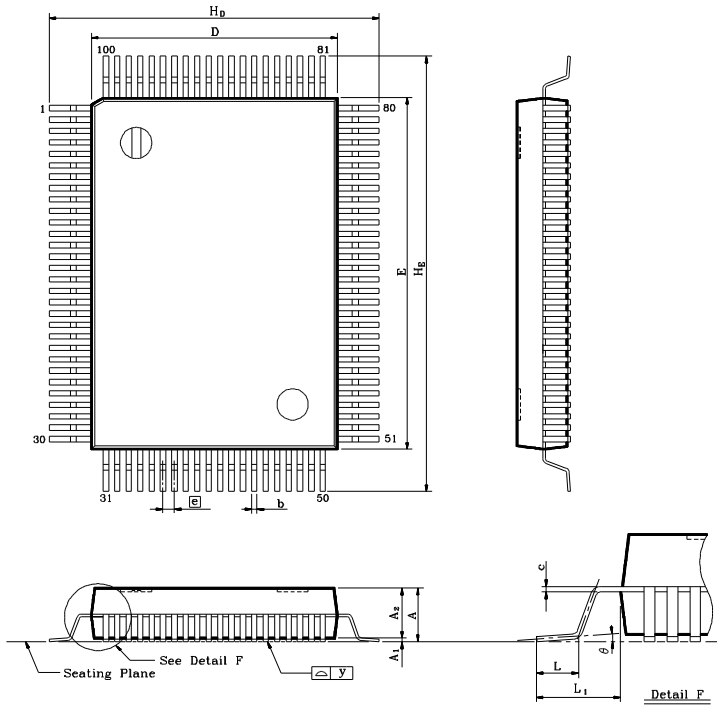

Symbol	Dimension(inch)			Dimension(mm)		
	Min	Typ	Max	Min	Typ	Max
A	0.106	0.118	0.130	2.70	3.00	3.30
A1	0.004	0.020	0.036	0.11	0.51	0.91
A2	0.102	0.112	0.122	2.60	2.85	3.10
b	0.007	0.012	0.017	0.18	0.30	0.42
c	0.002	0.006	0.010	0.04	0.15	0.26
D	0.541	0.551	0.561	13.75	14.00	14.25
E	0.778	0.787	0.797	19.75	20.00	20.25
e	0.020	0.026	0.031	0.50	0.65	0.80
HD	0.726	0.740	0.754	18.45	18.80	19.15
HE	0.963	0.976	0.990	24.45	24.80	25.15
L	0.039	0.047	0.055	1.00	1.20	1.40
L1	0.089	0.094	0.104	2.25	2.40	2.65
y	—	—	0.04	—	—	0.10
θ	0°	—	12°	0°	—	12°

**NOTE:**

- 1.Dimension D & E do not include interlead flash.
- 2.Dimension b does not include dambar protrusion /intrusion.
- 3.Controlling dimension:  
Millimeter on final visual inspection spec.
- 4.General appearance spec. should be based on final visual inspection spec.

**TITLE :**

100L QFP (14x20 mm\*\*2) FOOTPRINT 4.8 mm